

Dimensions (mm)

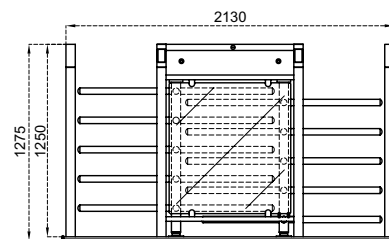
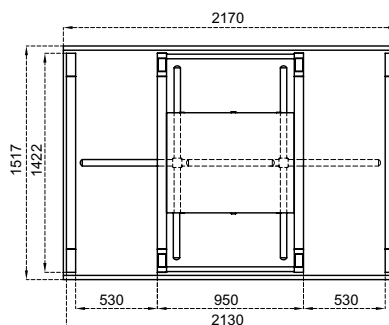

## Technical Features

<b>Place of Use</b>	Indoors, outdoors
<b>Operating Temperature, Humidity</b>	-20°C/+68°C (opt. -50°C with heater positive), RH 95% non-condensing.
<b>Operating Intensity</b>	100%, 7/24 use.

Built on box beam main carriers and contains waterproof protecting top lid.  
Four-section rotor (90°), each having 5 one by one demountable arms.

Combination options with different material choices:

Body / Arm Features	HT 400 D	HT 400 D-25	HT 400 D-100
<b>Body</b>	Electrostatic powder coating on hot-dip galvanized steel	Electrostatic powder coating on hot-dip galvanized steel	304 grade (opt. 316 grade)* stainless steel
<b>Arms</b>	Electrostatic powder coating on hot-dip galvanized steel, Ø42x2,5 mm.	304 grade (opt. 316 grade)* stainless steel, Ø40x2,0 mm.	304 grade (opt. 316 grade)* stainless steel, Ø40x2,0 mm.

(\*) Finishing : Satine brushed (opt. electrostatic powder coating on stainless steel).

<b>Indicators</b>	<b>Status - Direction Indicators</b> :   DOT MATRIX LED, standard. <b>Passage Indicators</b> :  LED standard.
<b>Power</b>	<b>Operating Voltage</b> : 110/220V AC 50/60 Hz. (±10%), 24V DC. <b>Consumption</b> : ~28W at stand-by, max ~50+50W (varies according to the options and accessories used).
<b>Operating Modes</b>	System operates bi-directionally (entry-exit). Operating modes can be adjusted through the buttons and screen on the control card. Entry - exit controlled                      Entry controlled, exit free                      Entry free, exit controlled Single input both directions use                      Entry - exit free
<b>Operating System</b>	Electromechanical manual operation (opt. electromechanical motorized operation).
<b>Control System</b>	All functions, parameters and operating modes can be adjusted through the buttons and screen on the control card. All inputs are opto-coupler protected. Controllable by dry contact (ground control). Compatible with all kinds of access control device. Optional RS232, RS485 or TCP/IP module is available.
<b>Flow Rate</b>	<b>Passage capacity (manual)</b> : max. 100 cycle/min. <b>Nominal</b> : ~50 pass/min. <b>Passage capacity (motorized)</b> : max. 68 cycle/min. <b>Nominal</b> : ~36 pass/min. (nominal passage rate can change depending on the access control system utilized)
<b>Emergency Mode</b>	System allows free passage (entry-exit) in both directions (fail safe). Works compatible with fire warning and similar systems. At the end of an emergency situation, system returns to its normal operating mode.
<b>Power-off Situation</b>	System allows free passage (entry-exit) in both directions (fail safe). Optionally, can be set (fail secure) as; entry-exit locked, entry free-exit locked, or entry locked-exit free. Free passage in chosen direction by manual override key in fail secure option is available.
<b>Weight</b>	~250 kg
<b>Optional Features and Accessories</b>	Motor driven unit, wireless remote control (receiver-transmitter), manual control, manual override key (with fail secure option), counter (with/without reset), card reader mounting bracket, passage completion sensor, contactless passage sensor (for motorized models), heater positive, bottom plate (standard or for forklift handling), battery back-up, 316 grade stainless steel, RS232-RS485-TCP/IP modules, limiter, different color choices.